

ECHELLE 0.750

REP	NB	DESIGNATION	MATIERE
01	1	CORPS	ALUMINIUM
02	1	BRAS	ALUMINIUM
03	1	AXE GALET	LAITON
04	1	ROULETTE DIA 14	LAITON
05	1	MORS MOBILE	LAITON
06	1	AXE GALET MOBILE	ACIER
07	1	ROULETTE D'APPUI	ACIER
08	1	VIS DE PRESSION	ACIER
09	1	MORS FIXE	LAITON
10	1	VIS MORS MOBILE	LAITON/ACIER
11	1	VIS GALET MOBILE	LAITON
12	1	PLAQUE BUTEE	LAITON
13	1	VIS DE PRESSION	ACIER
1	1	GOUPILLE ELASTIQUE 1 x 6	ACIER
2	1	RONDELLE 4x8x0.5	ACIER
3	1	RONDELLE M 4	ACIER
4	1	VIS H M4x12	ACIER
5	1	VIS H M4x25	ACIER
6	1	VIS Hc M3x4	ACIER
CINTREUSE TUBE 3			104g

VAPEUR 45		
CE DESSIN EST LA PROPRIETE DE VAPEUR 45 IL NE DOIT PAS ETRE COPIE OU DONNE A DES TIERS SANS LE CONSENTEMENT DE VAPEUR 45		
ECHELLE : 1/1		DESSINE PAR : RROCHART
		DATE : 28/02/21
OUTILLAGE		A4
CINTREUSE TUBE 3	CINT-00	1/3

REP	DESIGNATION
01	CORPS

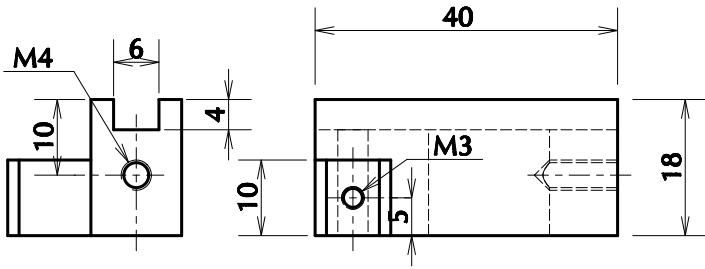

REP	DESIGNATION
03	AXE GALET

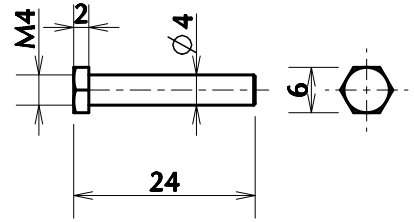

REP	DESIGNATION
02	BRAS

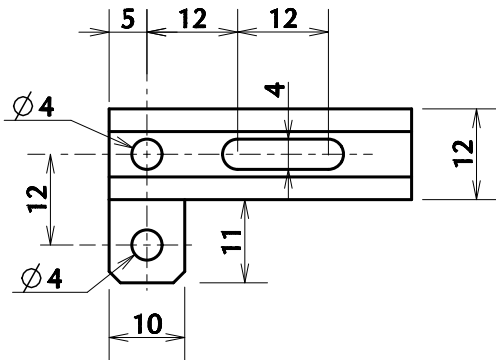

COUPE A-A

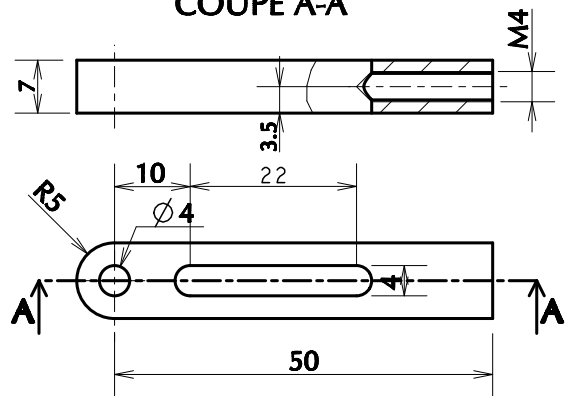

REP	DESIGNATION
04	ROULETTE DIA 14

ECHELLE 1.5

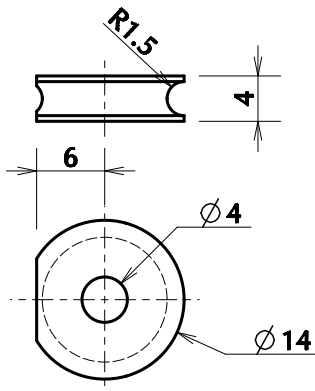

REP	DESIGNATION
05	MORS MOBILE

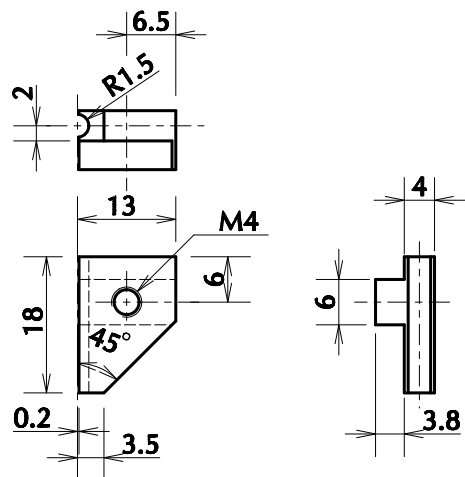

REP	DESIGNATION
07	ROULETTE D'APPUI

ECHELLE 1.5

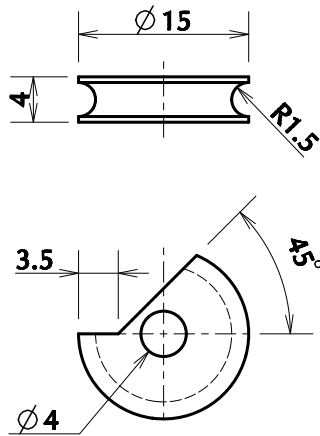

VAPEUR 45

CE DESSIN EST LA PROPRIETE DE VAPEUR 45
IL NE DOIT PAS ETRE COPIE OU DONNE A DES TIERS SANS LE CONSENTEMENT DE VAPEUR 45

ECHELLE : 1/1	DESSINE PAR : RROCHART	DATE : 28/02/21
------------------	---------------------------	--------------------

OUTILLAGE

A4

CINTREUSE TUBE 3	CINT-00	2/3
------------------	---------	-----

REP	DESIGNATION
06	AXE GALET MOBILE

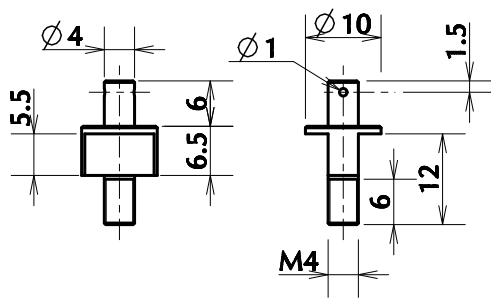

REP	DESIGNATION
09	MORS FIXE

ECHELLE 1.5

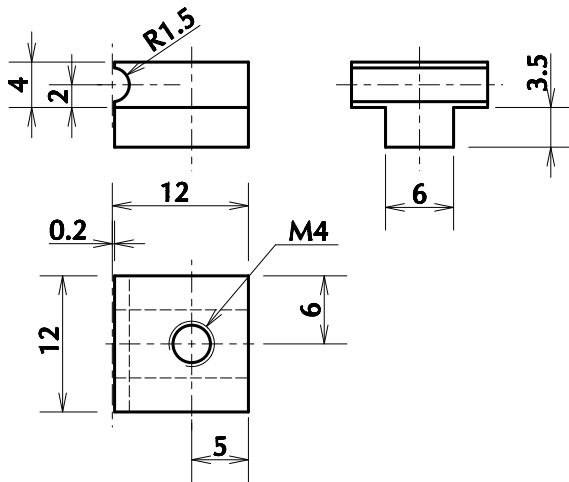

REP	DESIGNATION
11	VIS GALET MOBILE

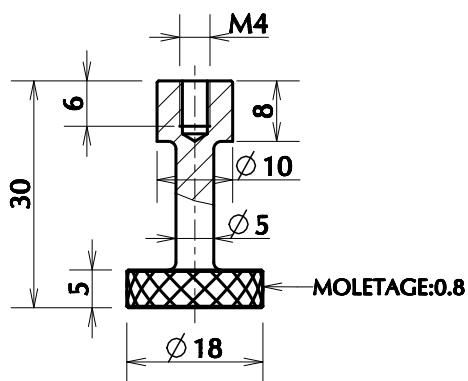

REP	DESIGNATION
08	VIS DE PRESSION

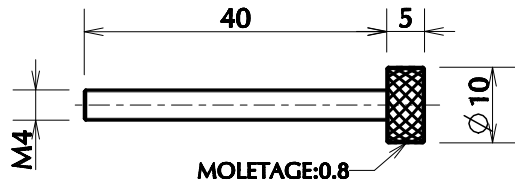

REP	DESIGNATION
13	VIS DE PRESSION

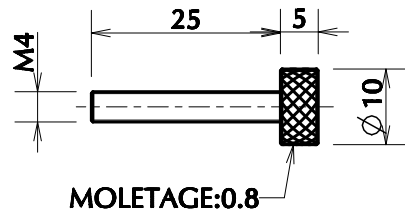

REP	DESIGNATION
10	VIS MORS MOBILE

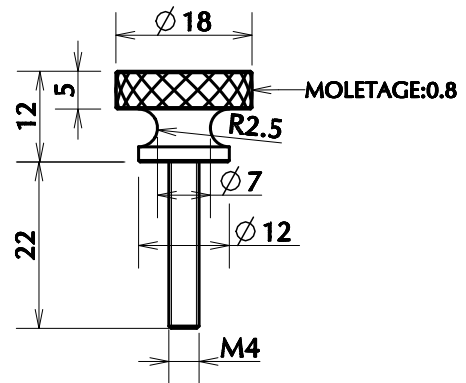

REP	DESIGNATION
12	PLAQUE BUTEE

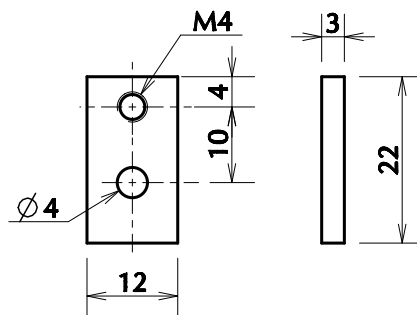

VAPEUR 45

CE DESSIN EST LA PROPRIETE DE VAPEUR 45
IL NE DOIT PAS ETRE COPIE OU DONNE A DES TIERS SANS LE CONSENTEMENT DE VAPEUR 45

ECHELLE : 1/1



DESSINE PAR : RROCHART

DATE : 28/02/21

OUTILLAGE

A4

CINTREUSE TUBE 3

CINT-00

3/3